

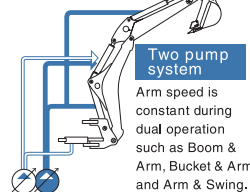

Backhoe

- The hydraulic system for backhoe operation is adapted from the Yanmar excavator.
- The variable displacement axial piston hydraulic pump allows smoother work performance with as much power as competitive machines one class larger.
- Hydraulic system has two pumps for smooth and fast operation with both 3-function and simultaneous movement.

Reliable Operation for Digging Performance

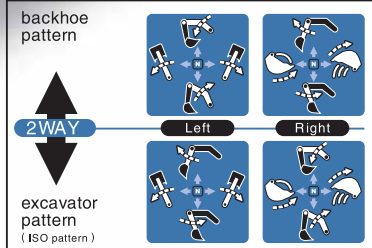

- Two control patterns, one for excavator and the other for backhoe use with quick change simply by replacing the link pins.

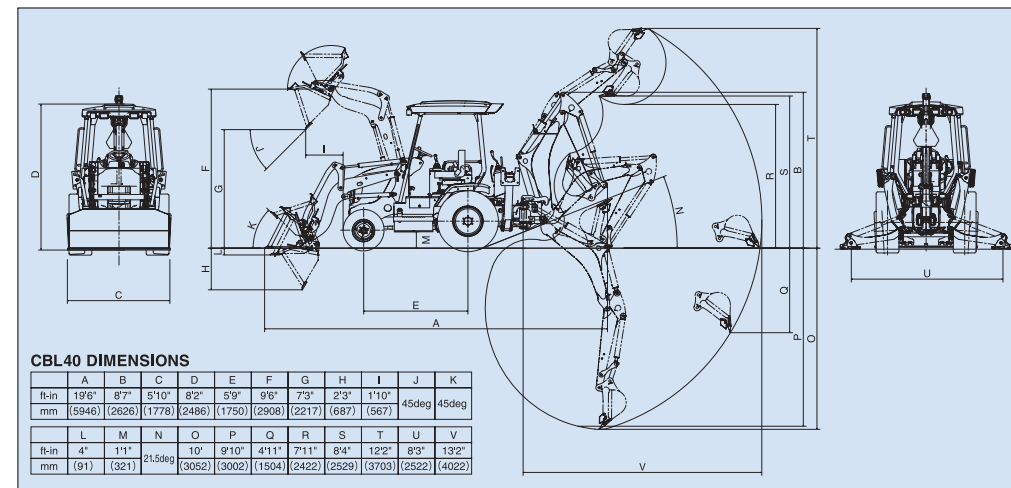

**CBL40 DIMENSIONS**

	A	B	C	D	E	F	G	H	I	J	K
ft-in	19'6"	8'7"	5'10"	8'2"	5'9"	9'6"	7'3"	2'3"	1'10"	45deg	45deg
mm	(5946)	(2626)	(1778)	(2486)	(1750)	(2908)	(2217)	(687)	(567)		
	L	M	N	O	P	Q	R	S	T	U	V
ft-in	4"	1'1"	21.5deg	10'	9'10"	4'11"	7'11"	8'4"	12'2"	8'3"	13'2"
mm	(91)	(321)		(3052)	(3002)	(1504)	(2422)	(2529)	(3703)	(2522)	(4022)

1. Operating Weight (Inc.operator 165lbs)	7750lbs (3515kg)	
2. Engine	Type	3TNV84T-XBL
	Rated output (Gross)	37.2hp / 27.7kW
3. Overall transport Length	19'6" (5946mm)	
4. Overall Width (w / Loader Bucket)	5'10" (1778mm)	
5. Overall transport Height	8'7" (2626mm)	
6. Wheelbase	5'9" (1750mm)	
7. Ground Clearance	1'1" (321mm)	
8. Transmission Type	Mechanical controlled Load sensing HMT	
9. Transmission Ranges / speeds	2 / infinite	
10. Max. Traveling Speed	Forward	13.7mph (22km / h)
	Reverse	7.8mph (12.5km / h)
11. Max. Traction Force	5622lbs (2550kgf)	
12. Fuel Tank Capacity	16.4gals (62L)	
13. Tire	Front	27x10.5-15.6Ply
	Rear	15-19.5.6ply
14. Rear PTO Output	[Option]	24hp / 540rpm
15. 3-point Hitch	[Option]	Category I

Loader		
16. Clearance with Bucket dumped	7'3" (2217mm)	
17. Max. Lift Height to Pivot Pin	9'6" (2908mm)	
18. Reach - Fully Raised	1'10" (567mm)	
19. Max. Dump Angle	45deg.	
20. Bucket Self-Leveling (Mechanical)	Standard	
21. Lift Capacity to Max. Height at Pivot Pin (w/o Bucket)	2866lbs (1300kgf)	
22. Breakout Force by Bucket Cylinder	4850lbs (2200kgf)	
23. Max. Oil Flow	11gpm (42L / min)	
24. Max. Pressure	3000PSI (210kgf / cm <sup>2</sup> )	

Backhoe		
25. Max. Digging Depth	10'0" (3052mm)	
26. Digging Depth / 2ft. Flat Bottom	9'10" (3000mm)	
27. Truck Loading Height	8'4" (2529mm)	
28. Max. Reach / ground level to Swing spot	13'2" (4022mm)	
29. Boom Swing Angle	180deg	
30. Max. Digging Force	Bucket	5798lbs (2630kgf)
	Arm	3582lbs (1625kgf)
31. Max. Oil Flow	11x2gpm (42x2L / min)	
32. Max. Pressure	3000PSI (210kgf / cm <sup>2</sup> )	
33. Number of Pumps	2x Piston (Variable)	

# Professional Use

## Compact Backhoe Loader

Designed from the ground up to be the best compact backhoe loader on the market. A superbly "drivable" machine.

The all-round Yanmar CBL40 backhoe loader is versatile on every jobsite. High reliability and performance you can rely on.

### Reliable Operation for Traveling and Loading

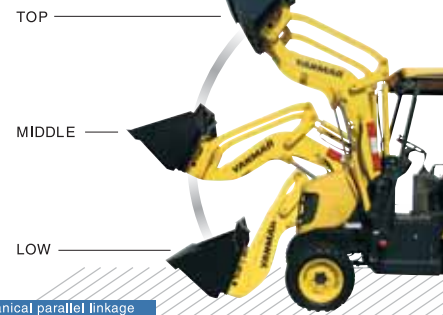

- Use of the newly developed HMT (hydro-mechanical transmission) means no range shifting during loader operation. The highly efficient transmission provides both low fuel consumption and high performance simultaneously.
- Mechanical parallel linkage for automatic bucket leveling. Lift arm raising and lowering with a single lever control, and the angle of the bucket or pallet fork is maintained for seamless loading and carrying.
- Easy travel operation by simply using the forward-reverse pedal. No range shifting is required during loader operation.
- Short nose and adjustable seat position allow excellent bucket visibility.
- Quick coupler is compatible with skidsteer attachments.



Short engine cover provides excellent bucket visibility.



The mechanical quick coupler expedites changing attachments.

Photo includes optional items.



Rear PTO for various attachments [Option]

### Reliable Operation for Landscaping

- Most category-1 3-point hitch attachments can be mounted with the backhoe removed, including box scrapers, rotary cutters, tillers and augers.



- Option
- Rock shaft
  - Rear PTO
  - 3-point hitch
- Attachment
- Box scraper
  - Rotary cutter
  - Tiller
  - Auger

### Reliable Operation for Servicing



Hydraulic oil is kept separate from the transmission oil to keep the hydraulic system clean.

### Reliable Operation for Operator Comfort

- A single-frame chassis like that of a large Tractor Loader Backhoe. This durable structure supports heavy loading and backhoe operation.



- Large operator space.
- Swiveling seat.
- Changeable seat direction while seated for loader and backhoe operation.



## COMPACT BACKHOE LOADERS CBL40

### Standard Equipment

- Loader
- Std. bucket (70in)
  - Self-leveling with mechanical parallel link
  - Mechanical quick coupler
  - 2WD-4WD axle
  - Differential lock
  - Back up alarm
  - Stop and tail lights
  - Flashing hazard / signal lights

### Backhoe

- Std. bucket (18in)
- Boom swing function
- Stabilizer with rubber pads
- 2way control pattern change
- Boom and swing transport lock

### Loader & Backhoe

- ROPS / FOPS Canopy
- Exterior canopy work lights
- Swiveling seat
- Seat belt
- Tie down loop
- Operation manual

### Optional Equipment

- Rock shaft (Category I ) with rate of drop / stop valve
- 3-point hitch (Category I )
- Rear PTO
- Auxiliary piping (for loader attachment)
- Auxiliary piping (for backhoe attachment)
- 4-in-1 multipurpose loader bucket
- Pallet fork
- Turf tire

